

IT9330 Series

Battery Charge and Discharge Testing Software

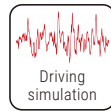
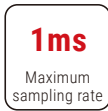

- >>> **Vmax : 2250V**
- >>> **Pmax : 10MW**
- >>> **Maximum Regenerative efficiency : up to 95%**

Features

(Equipped with 9330 software)

- Bidirectional & Regenerative design: up to 95% efficiency, THD<5%
- Voltage range up to 2250V
High power density: 420kW/37U
- Independent control of multi-channel and paralleable channels operation
- Seamless current switching, driving cycle simulation (FUDS,DST,WLTP,NEDC...)
- BMS communication function (CANBus, MODBUS)
- Powerful Hardware Protection: Anti-reverse connection, anti-spark, emergency stop and power-off crash prevention.
- No programming required, easy-to-use UI.
- Supports online parameter modification.
- Ready-to-use charge/discharge steps and test workflows.
- Battery spec management for quick parameter matching.

The ITECH ITS5300 Battery Testing System is designed for high-power battery testing and is equipped with the IT9330 battery charge and discharge testing software, making it suitable for various battery modules and packs. The system supports flexible programming, covering basic charge/discharge testing to complex drive cycle tests. It features a multi-channel architecture, allowing independent or parallel high-current operations, significantly enhancing testing flexibility and efficiency. With the energy recovery function, battery energy can be efficiently returned to the grid, reducing energy consumption and carbon emissions. The system provides multiple protections, including polarity check, over-voltage, and over-current, ensuring the safety and reliability of the testing process. Even in the event of sudden power failure or communication interruption, the system will automatically stop the test and safely save data, making it an ideal choice for power batteries, energy storage batteries, electric tricycles, and other battery types.

Applications

- Battery module & pack cycle life test
- Charge-rate & discharge-rate test
- Battery charging and discharging performance test at high and low temperatures
- Road condition curve simulation
- Battery capacity degradation test
- Battery BOL & recycling test

Your Power Testing Solution

IT9330 Battery Charge and Discharge Testing Software

Flexible System Configuration and Protections

The ITS5300 battery testing system offers high flexibility, allowing users to configure charge/discharge devices, data acquisition instruments, ACIR testers, temperature acquisition devices, and I/O equipment based on different testing scenarios. This enables users to create a customized testing platform. Additionally, the ITS5300 system is equipped with comprehensive hardware and software protection functions, such as power failure protection, emergency stop protection, anti-reverse connection protection, anti-ignition protection, OVP, UVP, which ensure the reliability and safety during battery testing.

* Software Platform: IT9330 Battery Charge/Discharge Testing Software

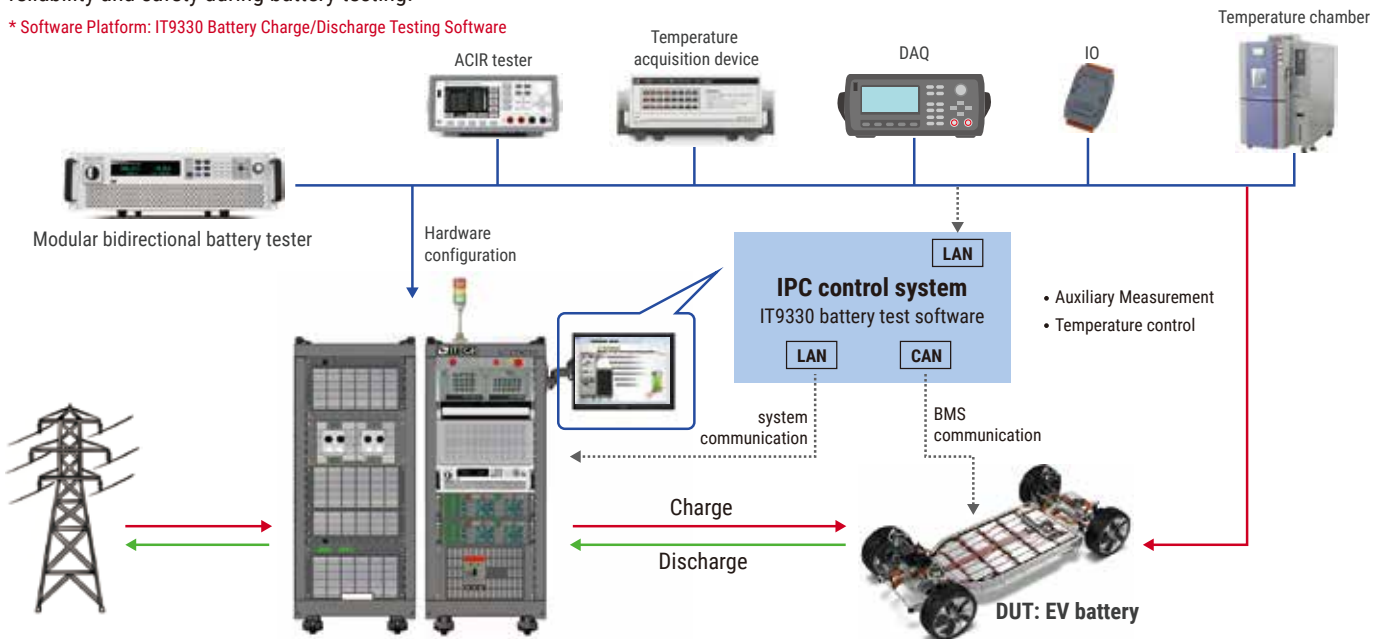

Anti-reverse connection and anti-sparking

The ITS5300 Battery Test System supports optional reverse-polarity and anti-sparking protection modules with multiple current ratings available. When used in conjunction with the battery test software, these optional modules enable comprehensive functions such as polarity detection, circuit pre-charging, and sense compensation. They effectively prevent sparking during cable connection and eliminate current backflow after test completion.

In addition, when the reverse-polarity and anti-sparking module is installed, the system can physically disconnect the battery from the test system in the event of an emergency stop activation or an AC power supply abnormality, further enhancing overall system safety and reliability.

Anti-power failure

The power failure protection module of the ITS5300 system provides a watchdog function that can monitor the communication status between the PC and system hardware units in real-time. In the event of an abnormal situation such as a PC crash or device freeze, this module will automatically stop all testing processes. Once the fault is resolved, the testing program can resume from the point of interruption without restarting, which improves the efficiency of test. Meanwhile, the test data before the abnormal interruption are well saved without any loss.

Three-color light alarm

The optional three-color light alarm on the ITS5300 battery test system can be used to visually warn the user to potential problems. You can program an audible alarm using your PC, so that even if testers are away from the test station, they can still get timely alerts. Red indicates that system protection has been triggered and the unit automatically stops operation; yellow indicates a warning, while green indicates that the system is in normal operation.

Emergency stop

The ITS5300 battery test system is equipped with an emergency stop module and a three-color light alarm. In the event of a test abnormality, the operator can use the emergency stop button to immediately disconnect both the AC and DC contactors between the system and the battery, ensuring the safety of the testing process.



Quickly Create Battery Testing Sequence without Programming Skills

The IT9330 software provides an advanced and efficient test solution. It features flexible configuration, an intuitive UI and real-time monitoring capabilities. The software has a rich set of built-in test steps (charging, discharging, reset...). It is easy to build test sequences by simply combining steps to realize complex tests such as battery cycle life test, charge/discharge rate test, temperature characterization test and driving cycle simulation test. Compared with traditional software, IT9330 does not require any programming skills, so your time is well saved to one-third of that of conventional software operation, which dramatically improves test efficiency and operation convenience.

Operation mode

- CC/CV/CR/CP/CC-CV/CP-CV/Pulse /Ramp
- Charge mode: CC/CV/CP/CC-CV/Pulse/Ramp
- Driving cycle simulation test
- DCIR/ACIR test
- BMS communication function (CANBus or Modbus protocol)
- Multiple Goto outlets/loop nesting
- Reset

Cut-off conditions

- Voltage/current/time/capacity/energy/temperature auxiliary measurement function
- Formula combination
- BMS Information
- Rate of change: $\Delta T/\Delta V/\Delta I/\Delta C$

Protections

- Channel: OVP/UVP/OC/OCV/OPP/ $\Delta V/\Delta I$
- Single: OVP/UVP/OTP/ ΔV

Data storage

- Independent sampling rate of channel and auxiliary measurement
- Saving conditions: $\Delta T/\Delta V/\Delta I/\Delta C$

More

- Auxiliary Measurement Functions

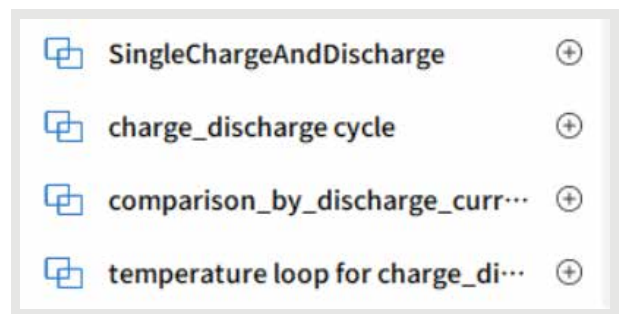
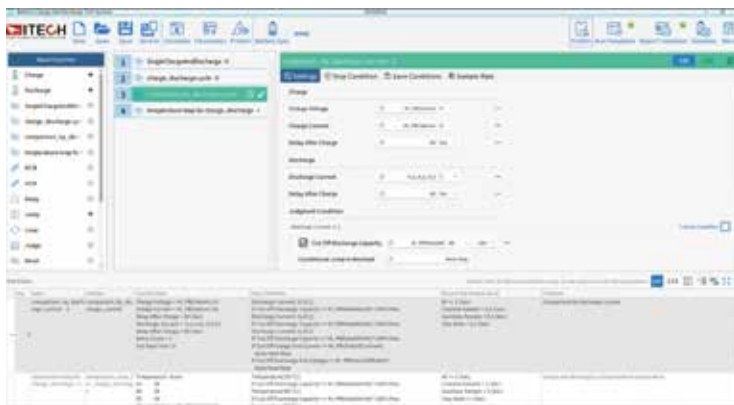

Pre-configured 'Test Flow' for Immediate Use

Multi-channel/parallel operation

- Run/stop control for each channel independently
- Each channel can independently recall different test sequences
- apply the same or different test sequence for multi-channels
- Supports adding channels during operation, instant activation.

Channel	Function Block	Status	Enter status	Cycle	Test Time(S)	Stop Run Time(S)	Voltage(V)	Current(A)	Power(W)	DCIR(m)	Chamber Temp(°C)
CH1	1.SingleChargeAndDischarge - 1.SingleCharge_Discharge	Running	●	1	00:00:20	00:00:20	11.290	1.919	21.471	0.000	0.000000
CH2	1.SingleChargeAndDischarge - 1.SingleCharge_Discharge	Running	●	1	00:00:20	00:00:20	11.201	1.919	21.509	0.000	0.000000
CH3	1.SingleChargeAndDischarge - 1.SingleCharge_Discharge	Running	●	1	00:00:20	00:00:20	11.207	1.919	21.534	0.000	0.000000
CH4	1.SingleChargeAndDischarge - 1.SingleCharge_Discharge	Running	●	1	00:00:20	00:00:20	11.261	1.919	21.521	0.000	0.000000

Your Power Testing Solution

IT9330 Battery Charge and Discharge Testing Software

Driving Cycle Simulation

The IT9330 software allows the design and execution of simulation tests based on real road conditions to accurately reflect the performance of EV batteries in actual use. These conditions are often characterized by high speed, dynamics and irregularity, and frequent switching between driving and braking (charge/discharge current switching), thus posing a great challenge to the switching speed of the battery test system.

IT9330 software has built-in 'road condition simulation curves' and it can:

- allow import of 10,000,000 points of I-t or P-t excel data.
- seamlessly switch between positive and negative currents
- achieve the current switching speed (-90% to 90%): <10ms (no overshoot)
- simulate various road conditions: FUDS, NEDC, WLTP, DST, HPPC and more

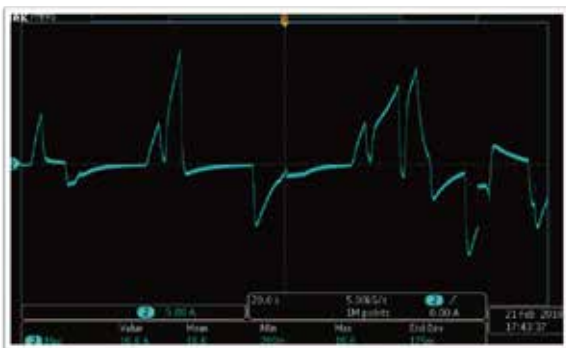

IT9330 1:1 Simulation EV Driving Current Curve

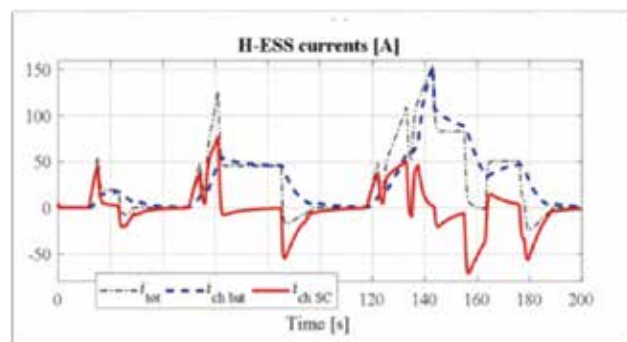

Real Curves required by EV drivers

One-Click Battery Spec Switch, Automatic Test Flow Adaptation

The IT9330 Battery Charge/Discharge Testing Software now supports battery specification management, perfectly adapting to the testing needs of different battery models. Whether it's 18650 or 21700, users can easily create a battery specification by setting parameters such as maximum charge voltage, maximum continuous discharge current, and nominal capacity. Once the battery spec is created, simply select the battery model during testing, and the IT9330 software will automatically sync the parameters to the test flow. This eliminates the need to manually adjust battery parameters in each test step, significantly saving engineers' time and improving efficiency. The entire test flow becomes simpler and easier to manage. This feature is especially useful for battery testing institutions and companies with multiple battery models, helping them quickly respond to different testing needs, streamline workflows, and enhance test accuracy and efficiency.

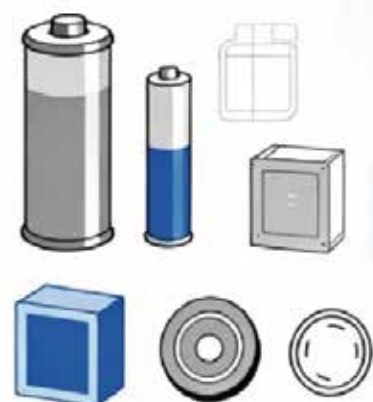
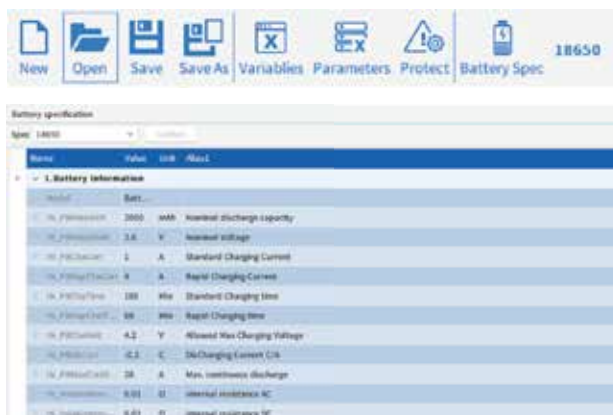

BMS Communication Function

The IT9330 battery testing system supports communication interaction with the BMS via CANBus and MODBus protocols, enabling real-time acquisition, recording, BMS information. This data can be used as the basis for step Goto, alarm triggers, and charge/discharge cut-off conditions.

- Easily import CAN messages in .dbc format and configure them
- During software operation, BMS information such as SoC, SoH, and individual cell temperature can be displayed in real-time
- Acquire and save CAN message information
- Send messages to wake up and start BMS
- Supports using BMS information as stop conditions, alarm conditions, and protection conditions during program execution



Online Parameter Modification

The IT9330 Battery Testing Software offers powerful online parameter modification, providing greater flexibility and convenience during testing. Whether at any stage of charge/discharge testing, you can adjust test parameters such as voltage, current, and cutoff conditions in real-time without stopping the test or reconfiguring the flow.

- Real-Time Adjustments: Modify parameters during testing without interruptions, saving time.
- Flexibility: No need to restart or modify the test flow; adjust conditions on the fly.
- Precise Control: Dynamically adjust parameters based on test progress to ensure accuracy and consistency.

Whether responding to unexpected situations or optimizing based on real-time data, the online parameter modification feature enables engineers to quickly adapt, ensuring more precise and reliable test results.

Multiple Auxiliary Measurement Function Modules

Digital I/O

The digital I/O option is typically used to trigger external conditions, such as controlling the activation or deactivation of external relays or providing trigger signals for test chambers or other third-party hardware. This option supports both TTL and relay modes.

Equalizing charge and discharge equipment

The equalizing charge and discharge equipment is typically used for the equalizing test of battery cell. When the voltage of certain cells in a battery pack is too low or too high, to ensure the consistency of the battery's internal voltage, ITECH's equalizing charge and discharge equipment can be of help to charge or discharge the individual cell, thereby restoring the equalizing state.

Auxiliary voltage measurement

The auxiliary voltage measurement channel can be used to measure the cell voltage in battery packs. The voltage values can be recorded in the result file or used for further experiment.

Temperature measurement channel

The temperature measurement channel can measure the temperature at any point in the experimental setup using a thermocouple module (Type T or Type K) or a thermistor module. The temperature values can be recorded in the test report or used as condition for test protection/alarms.

AC internal resistance tester

Online measurement refers to real-time monitoring of the AC internal resistance of the cells during the charge and discharge cycles of a battery pack. Compared to traditional offline measurement methods, this online detection can more accurately reflect the internal resistance characteristics of the cells during actual use of the battery pack.

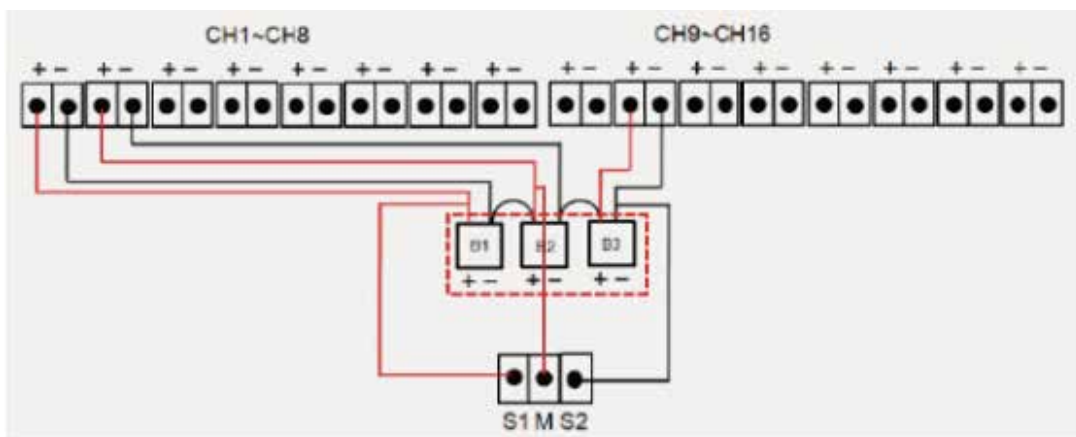

The third-party temperature chamber equipment

The third-party temperature chamber control function enables the ITS5300 system to communicate with third-party temperature chamber controllers during testing. This function allows users to set conditions such as the temperature and humidity of the chamber, providing the external environment required for battery testing.

Application of ITS5300 Battery Test System

Battery capacity test

Because the battery capacity is affected by the ambient temperature and discharge rate, the capacity test is usually combined with the temperature characteristics and discharge rate. The higher the temperature, the larger the capacity; the larger the discharge rate, the smaller the capacity. ITS5300 system can integrate the control of thermostat, and simulate the environment of normal temperature, high temperature and low temperature. ITS5300 system provides the function of user-defined X-axis and Y-axis parameter categories. You can set the Y-axis as the capacity and the X-axis as the time to obtain the corresponding curve.

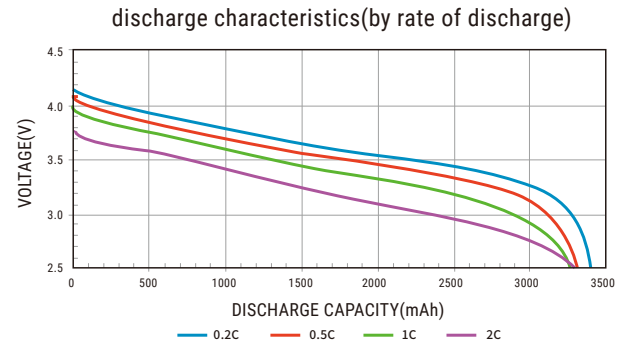

Battery cycle life test

The battery cycle life test is one of the necessary test items for the battery. When the capacity declines to 80% of the original, the life can be considered to end, and the battery life is generally obtained by cyclic charging and discharging. Speaking of the factors affecting battery life, in addition to temperature and frequency of use, dynamic operating conditions will also accelerate battery aging. ITS5300 provides pulse charge and discharge mode and edit steps according to rich charge, rich discharge curve marked in the ISO12405-4-2018 standard.

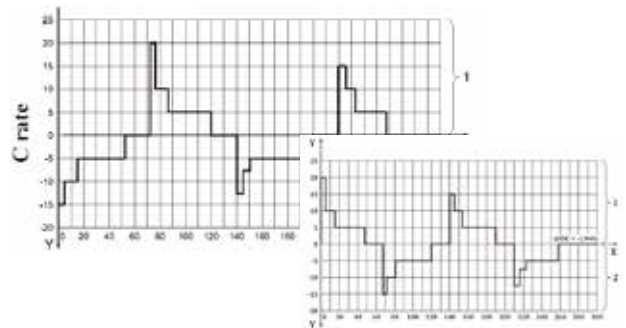

HPPC test

The HPPC test is a very important test in FreedomCar. It is used to test the performance of hybrid and pure electric vehicles. It is a common test item when evaluating battery systems / modules or single cells. The main test purpose of HPPC is to establish the relationship between discharge depth and power within the battery voltage range. The second is to use the voltage and current curve to establish a function of the discharge depth, conductive resistance and polarization resistance. Then it can evaluate power degradation during life testing by the resistance measurement results. It is a detection method for fully analyzing power batteries. ITS5300 supports users to edit discharge pulse and feedback pulse value according to HPPC curve.

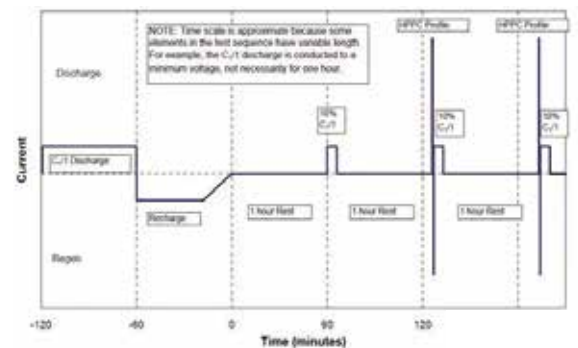

Equalizing charge and discharge test

The differences in the manufacturing and use processes will cause inconsistencies in the cells inside the battery, which are manifested in terms of cell capacity, internal resistance, and charge and discharge efficiency. In order to avoid the life and capacity loss of the overall battery pack caused by degradation of individual performance, BMS generally has a balanced function. At present, the balancing strategy of each BMS is different. The individual cells can be balanced with each other or an energy-consuming method may also be adopted. A resistor is connected to the back end of each cell to consume the power of the cell with a higher power. ITS5300 can accept the balanced start and stop signals of the BMS during the charging and discharging process. Adopting balancing operation of the BMS during the charging and discharging can prevent large differences in battery cells and extend battery life.

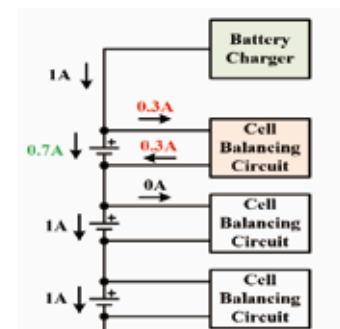

Specification

HV pack (for battery packs testing from 500V to 1500V, with IT6000C series hardware)

	ITS5300-500-720	ITS5300-800-450	ITS5300-1500-240
Voltage	500V	800V	1500V
Current	±720A	±450A	±240A
Power	108kW	108kW	108kW
Measurement accuracy (U)	0.02%+0.02%FS	0.02%+0.02%FS	0.02%+0.02%FS
Measurement accuracy (I)	0.1%FS	0.1%FS	0.1%FS
Anti-Reverse&Anti-Sparking	√	√	√
Emergency Stop Protection	√	√	√
BMS Communication Interaction(CAN Protocol)	√	√	√
PC	√	√	√
Channel number	1CH	1CH	1CH
AC input	3phase + PE	3phase + PE	3phase + PE
AC input current (per phase) (380Vac±10% or 400Vac±10%)	206A max	206A max	206A max
AC input voltage (250Vac~500Vac)	Option	Option	Option
Under 480Vac±10% input condition	164A max	164A max	164A max
Sizes	37U	37U	37U

	ITS5300-500-1320	ITS5300-800-825	ITS5300-1500-440
Voltage	500V	800V	1500V
Current	±1320A	±825A	±440A
Power	198kW	198kW	198kW
Measurement accuracy (U)	0.02%+0.02%FS	0.02%+0.02%FS	0.02%+0.02%FS
Measurement accuracy (I)	0.1%FS	0.1%FS	0.1%FS
Anti-Reverse&Anti-Sparking	√	√	√
Emergency Stop Protection	√	√	√
BMS Communication Interaction(CAN Protocol)	√	√	√
PC	√	√	√
Channel number	1CH	1CH	1CH
AC input	3phase + PE	3phase + PE	3phase + PE
AC input current (per phase) (380Vac±10% or 400Vac±10%)	376A max	376A max	376A max
AC input voltage (250Vac~500Vac)	Option	Option	Option
Under 480Vac±10% input condition	298A max	298A max	298A max
Sizes	37U+27U	37U+27U	37U+27U

This information is subject to change without notice. For more information, please contact ITECH.

Taipei

Add: No.918, Zhongzheng Rd., Zhonghe Dist., New Taipei City 235,

Taiwan

Web: www.itechate.com

TEL: +886-3-6684333

E-mail: info@itechate.com



ITECH Web



ITECH Facebook



ITECH LinkedIn